

felton[®]

WWW.FELTON.COM.MY

TIMBER BLINDS

BLINDS & SHADES GLOSSARY



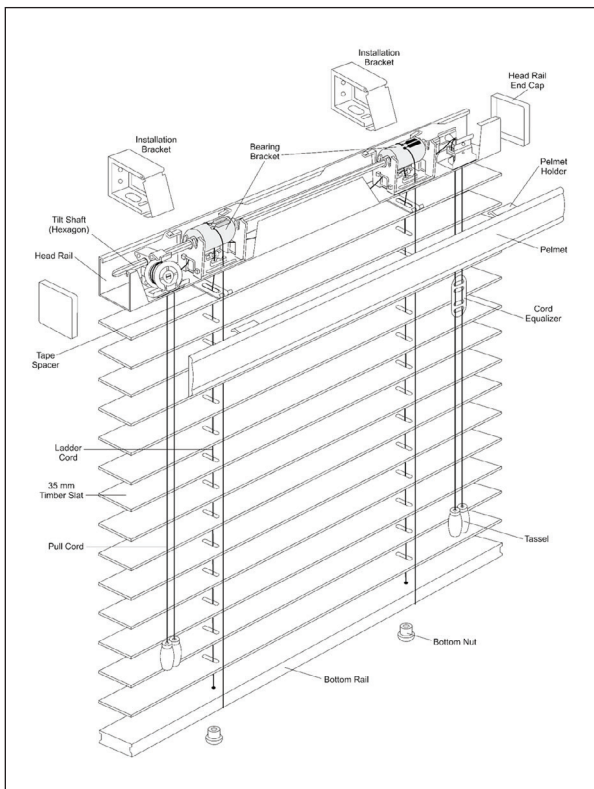

TIMBER BLINDS

Window treatment such as curtains and blinds have the ability to change the environment of the room. Timber blinds are popular choice for people, timber blinds have plenty of natural texture and functional benefits. Timber blinds are the better choice for control sunlight and own privacy.

Wooden blinds will give your home a vintage style and will go with a variety of different interior types. Our selection includes water-resistant faux wooden blinds that are ideal for kitchens and bathrooms, as well as real wooden blinds crafted from woods sourced from responsibly managed forests. Both materials have a clean, modern appearance, allow natural light into your home, and provide seclusion. We're confident you'll like having them in your home.

Felton Blinds is a Malaysian company that specialises in stylish, handmade window blinds. Our window blinds are created by skilled artisans from high-quality domestic and imported materials.

THE MEASUREMENT

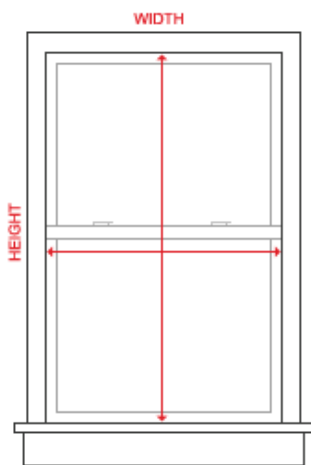

HOW TO MEASURE INSIDE MOUNT

1. Measure the width inside the window opening at the top, middle and bottom. Take the narrowest of the three width measurements, and round down to the nearest 1/8".
2. Measure the height inside the window opening from the top of the window opening to the window sill three times. Measure once on the left, at the center, and on the right and take the longest of the three measurements. If you prefer to keep the blind from resting on the sill deduct a 1/4" from the height. If your window does not have a sill, measure to the point you would like the blind to reach.
3. Measure the window on the diagonal. If the two diagonal dimensions differ significantly, it may be necessary to order an outside mount for optimal light control and privacy. See measuring instructions below.
4. Do not take any allowances on the height or width. The factory will take all required allowances on an inside mount for mounting and operating clearance.

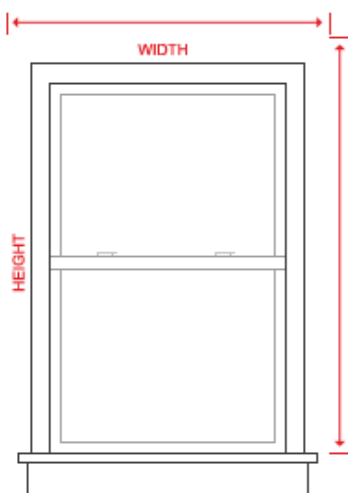

HOW TO MEASURE INSIDE MOUNT

1. Measure the width inside the window opening at the top, middle and bottom. Take the narrowest of the three width measurements, and round down to the nearest 1/8".
2. Measure the height inside the window opening from the top of the window opening to the window sill three times. Measure once on the left, at the center, and on the right and take the longest of the three measurements. If you prefer to keep the blind from resting on the sill deduct a 1/4" from the height. If your window does not have a sill, measure to the point you would like the blind to reach.
3. Measure the window on the diagonal. If the two diagonal dimensions differ significantly, it may be necessary to order an outside mount for optimal light control and privacy. See measuring instructions below.
4. Do not take any allowances on the height or width. The factory will take all required allowances on an inside mount for mounting and operating clearance.

MIX & MATCH YOUR OWN BLINDS

Choosing the right window treatment often depends on five main characteristics:

- 1. Slat Width**
Choose slat width suit your style.
- 2. Slat Colours**
Choose slat colors suit your style.
- 3. Braided Ladder**
Choose default braided ladder colors.
- 4. Decorative Tape**
Adding decorative tape to add more tidy looks.
- 5. Tilt Cord**
Finally choose tilt cord for your blinds.

Go through each of the steps below to make your selection. Based on your choice, our Product Advisor will offer you a primary recommendation, as well as additional solutions below.

SLAT WIDTH



50MM

35MM

SLAT COLOURS

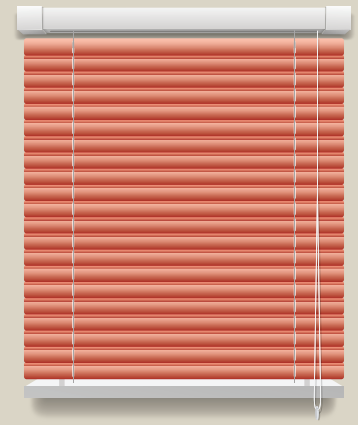

BRAIDED LADDER

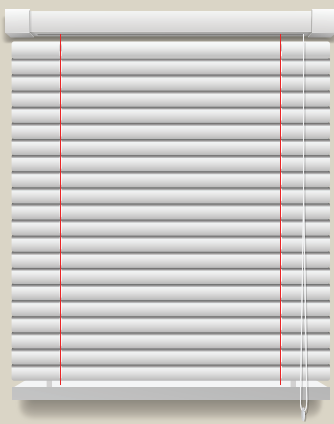

DECORATIVE TAPE

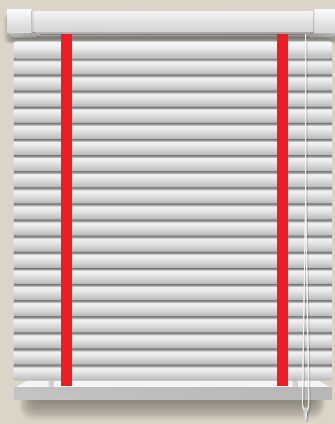

TILT CORD

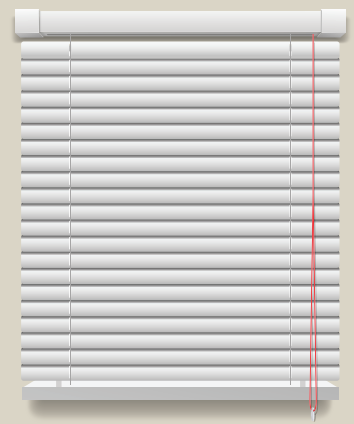

TILT CORD

String is used to open and close wooden blinds. As a result, it's critical to make sure you select the appropriate string when selecting your window covering.



Noted :- Due to the use of various fabric batches, colour may fluctuate slightly from photos. Possibly as a result of the lighting and screen settings used for the photoshoot.

BRAIDED LADDER

Two external strings holding a horizontal blind in place. The bottom rail of the braided ladder is where it ends after passing through the middle of the slats and being attached at the headrail. Decorative tapes can frequently be used to cover these.

Noted :- Due to the use of various fabric batches, colour may fluctuate slightly from photos. Possibly as a result of the lighting and screen settings used for the photoshoot.

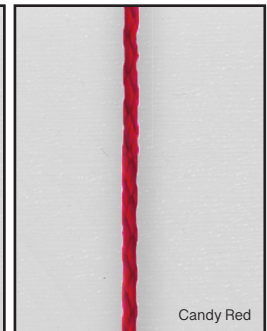
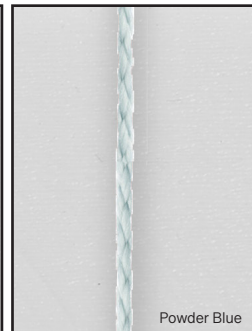
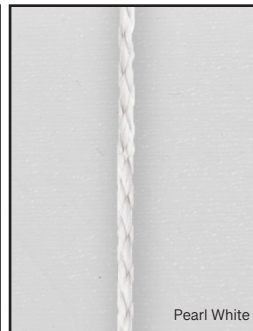
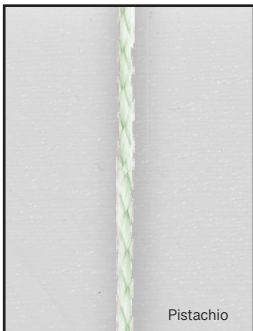
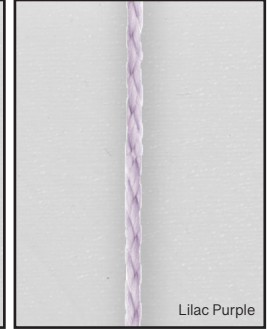
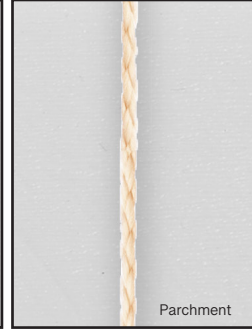
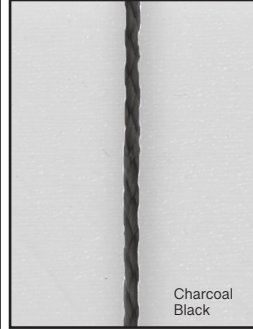
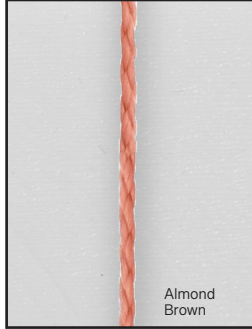
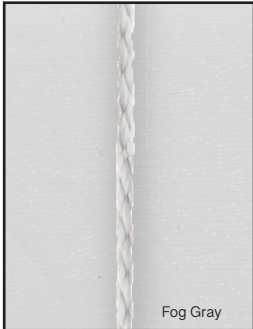
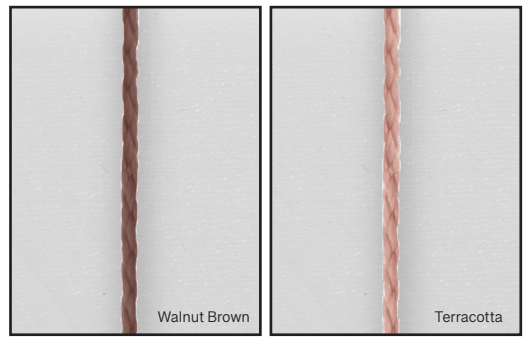

DECORATIVE TAPE

Wooden blind decorative tapes, sometimes referred to as "ladder tapes" are vertical fabric strips that pass between the slats of your wooden blind from top to bottom. By holding the slats in place, these tapes support the structure and maintain the slats' symmetry and order.

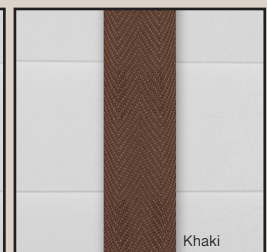
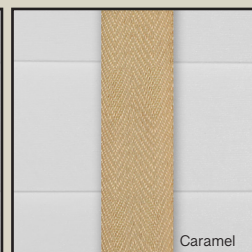
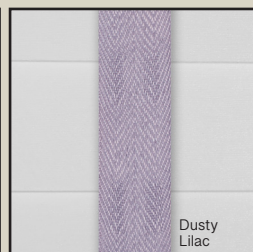
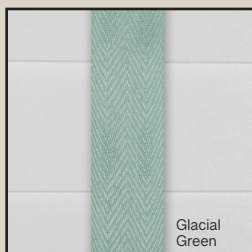
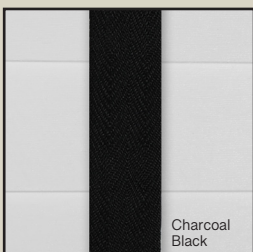
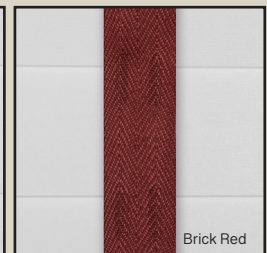
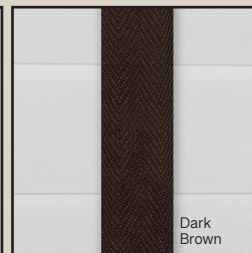
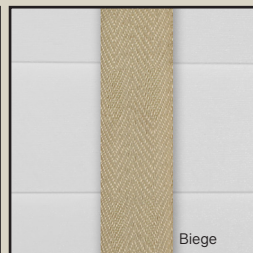
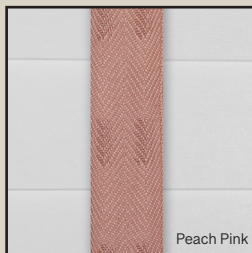
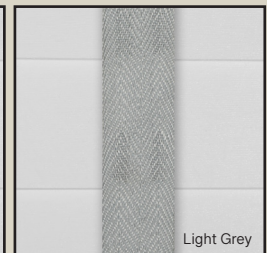
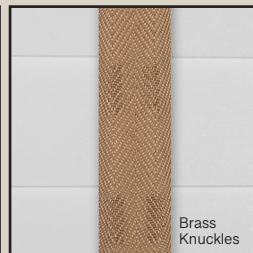
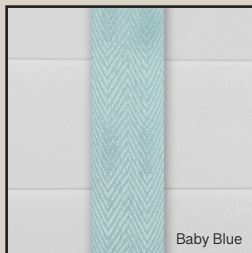
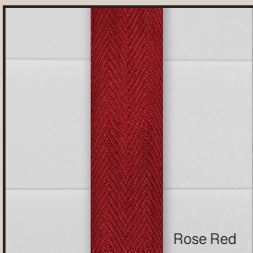
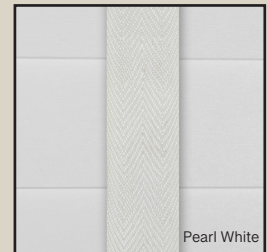

WOODEN SLAT

WHITE

The basic yet attractive combination of white wood and white decorative tapes allows you to pair these blinds with any range of colors while still appearing fantastic. White wood truly does help you create a design that will last through the seasons.

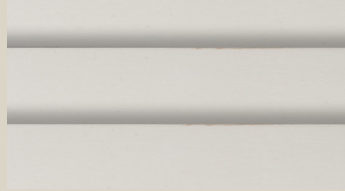

ROSEWOOD

Rosewood is a gorgeous combination of toffee and warm brown tones. It will hang at the window so elegantly. The colouring here can't help but offer a rich tone to a room and it will look wonderful at any window that needs a practical yet gorgeous blinds.



NATURAL

The soft tone of neutral wood color's creamy richness gives your interior a simple look. Complementary coloured tapes are added to complete the design for an elegant finish that goes well with any aesthetic.

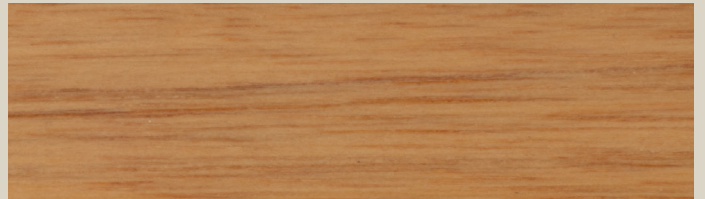

GOLDEN OAK

Simply visualizing these Golden Oak Wood Impressions blinds makes you feel comfy. It has a natural charm with shades of golden honey and caramel. In addition, it functions quite efficiently in addition to having a beautiful grained texture and a realistic appearance.

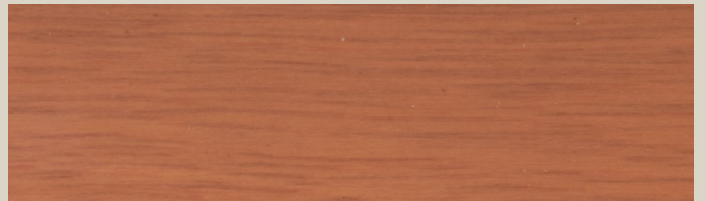
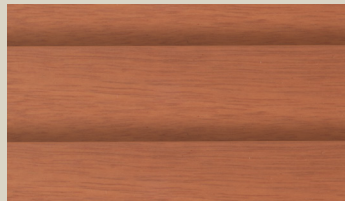

DARK WALNUT

Instantly add warmth and elegance to your home interior with the Dark Walnut slat colours. The fabulous brown shade will give any bedroom, living room, or kitchen that stunning touch.

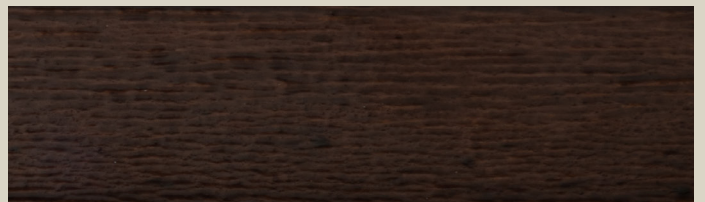
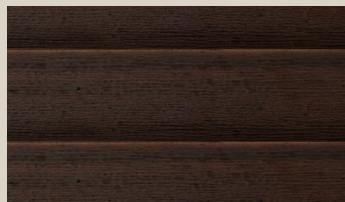

DARK COFFEE

Our Dark Coffee, which is rich and decadent, will spread refinement and luxury throughout your house. The colour schemes enable seamless matching for use throughout the interior.

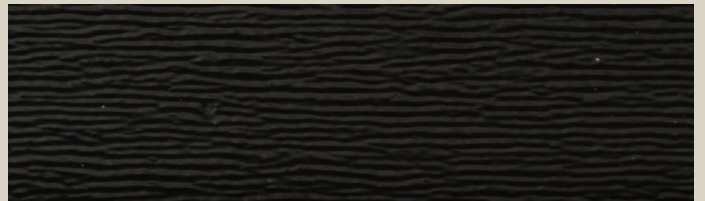
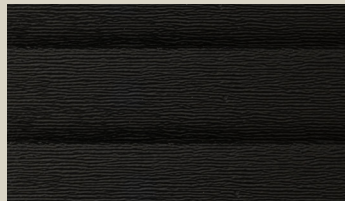

TEAK

Darker tones run through each slat of this classy Impressions Teak wood blind, giving it an authentic, textured appearance and a sleek, wood grain effect. The blind has a stylish look and emerges with complementary chocolate tapes. It is ideal for adding a bit of extra of style and class to any design scheme.

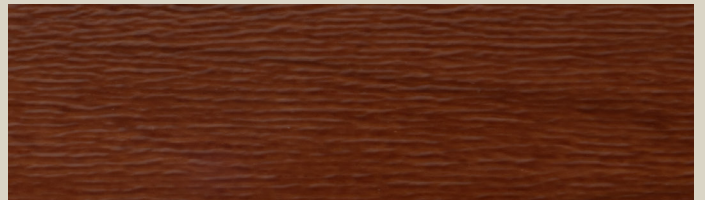
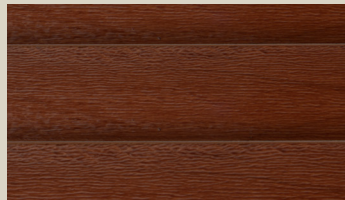

WALNUT

This modest yet attractive window treatment, in an organic wood shade, combines function and aesthetic in equal measure. Its wood tone makes it ideal for completing a cosy area, offering a stylish contrast to basic, bright decor, or serving as the ideal partner to dark wooden furnishings and flooring.

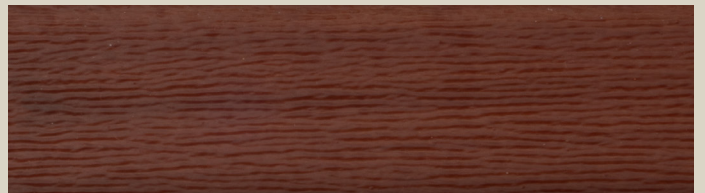

TIGER EYE

This medium shaded tone combines the sturdy elegance of modern manufacturing with the natural beauty. The warm colour gives off warmth, and the geometric clarity and clean lines give it a stylishly modern appearance.

